



**AVERY
DENNISON**

Fastener
Solutions

15" Standard Cable Ties Marketing Specifications

For the following part numbers:

08416-0
08416-HHBN
08427-0
08428-0
10036-0
10037-0
10408-0

August 1, 2019

AVERY DENNISON MARKETING SPECIFICATION

THE SUBJECT MATTER DISCLOSED HEREIN EMBODIES PROPRIETARY INFORMATION WHICH IS THE CONFIDENTIAL PROPERTY OF THE AVERY DENNISON CO. NONE OF WHICH SHALL BE COPIED, REPRODUCED, DISCLOSED TO OTHERS, PUBLISHED OR USED IN WHOLE OR IN PART, FOR ANY PURPOSE OTHER THAN THAT FOR WHICH IT IS BEING MADE AVAILABLE WITHOUT THE EXPRESS ADVANCE WRITTEN PERMISSION OF A DULY AUTHORIZED AGENT OF THE COMPANY. THIS DOCUMENT IS THE PROPERTY OF THE AVERY DENNISON CO. AND IS TO BE RETURNED TO THE COMPANY ON DEMAND.

HISTORY		
REV.	DATE	DESCRIPTION
K	1.30.15	REDRAWN IN NEW FORMAT, ADDED UL INFORMATION AND LOGO
L	3.17.16	UPDATED DIM 5 TO BE 343.5mm TO MATCH NOMINAL MOLD DIM; UPDATED DIM 1 TO BE 7.3(TAKEN FROM THE BASE OF THE CABLE TIE HEAD)

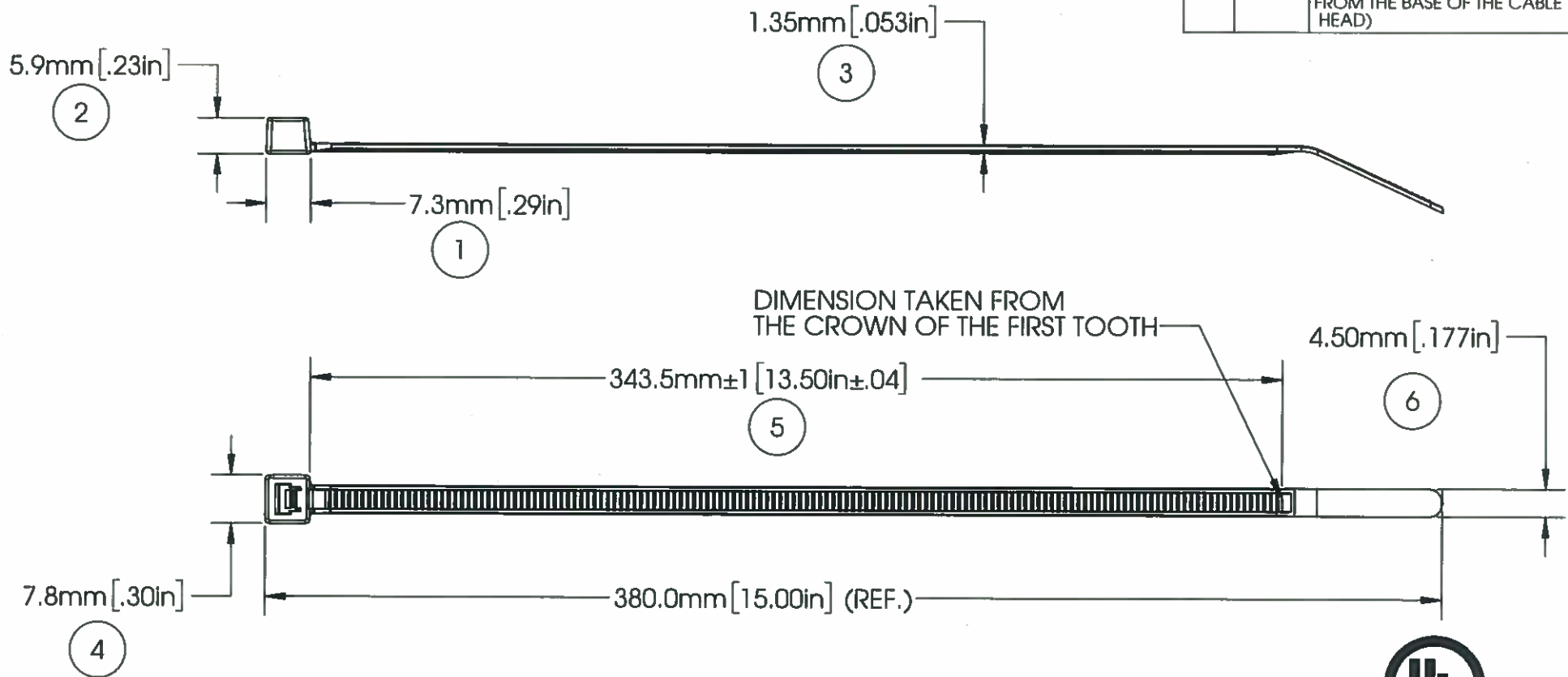

NOTE: THESE CABLE TIES ARE PLENUM RATED AND HAVE A FLAMMABILITY RATING OF V-2

LOOP TENSILE STRENGTH:	50 LBF/220 N MIN. PER AS-23190
OPERATING TEMP RANGE:	-40°F (-40°C) TO 221°F (105°C)
MIN. INSTALLATION TEMP:	32°F (0°C)
WEIGHT:	2.35 g. / (0.0800 oz)
BUNDLE DIAMETER:	Ø 1.6mm TO Ø 101.6mm (0.06" - 4")
TOOL:	12001-0 - HAND TOOL 12500-0 - PNEUMATIC TOOL
TOOL TENSION SETTING:	6-8
PACKAGING:	100/BAG, 1000/CASE

APPROVALS:	ENG. APPR. <i>[Signature]</i> 3/17/16
	Q.A. APPR. <i>[Signature]</i> 3/17/16

AVERY DENNISON
FASTENER DIVISION
FITCHBURG, MA 01420 U.S.A.
TEL: 1-800-225-5913
FAX: 978-353-8157

SPECIFIED TOLERANCES ARE:		MATERIAL	DESCRIPTION
.XX ± .03 in	.X ± .7 mm	NYLON 66, HEAT STABILIZED	15" CABLE TIE, STANDARD
.XXX ± .010 in	.XX ± .25 mm	COLOR	STOCK NO.
ANGULAR: ± 2°		BLACK	08416-0
			REV. L

5

4

3

2

1

AVERY DENNISON MARKETING SPECIFICATION

HISTORY

REV.	DATE	DESCRIPTION
A	2/27/17	INITIAL RELEASE

THE SUBJECT MATTER DISCLOSED HEREIN EMBODIES PROPRIETARY INFORMATION WHICH IS THE CONFIDENTIAL PROPERTY OF THE AVERY DENNISON CO. NONE OF WHICH SHALL BE COPIED, REPRODUCED, DISCLOSED TO OTHERS, PUBLISHED OR USED IN WHOLE OR IN PART, FOR ANY PURPOSE OTHER THAN THAT FOR WHICH IT IS BEING MADE AVAILABLE WITHOUT THE EXPRESS ADVANCE WRITTEN PERMISSION OF A DULY AUTHORIZED AGENT OF THE COMPANY. THIS DOCUMENT IS THE PROPERTY OF THE AVERY DENNISON CO. AND IS TO BE RETURNED TO THE COMPANY ON DEMAND.

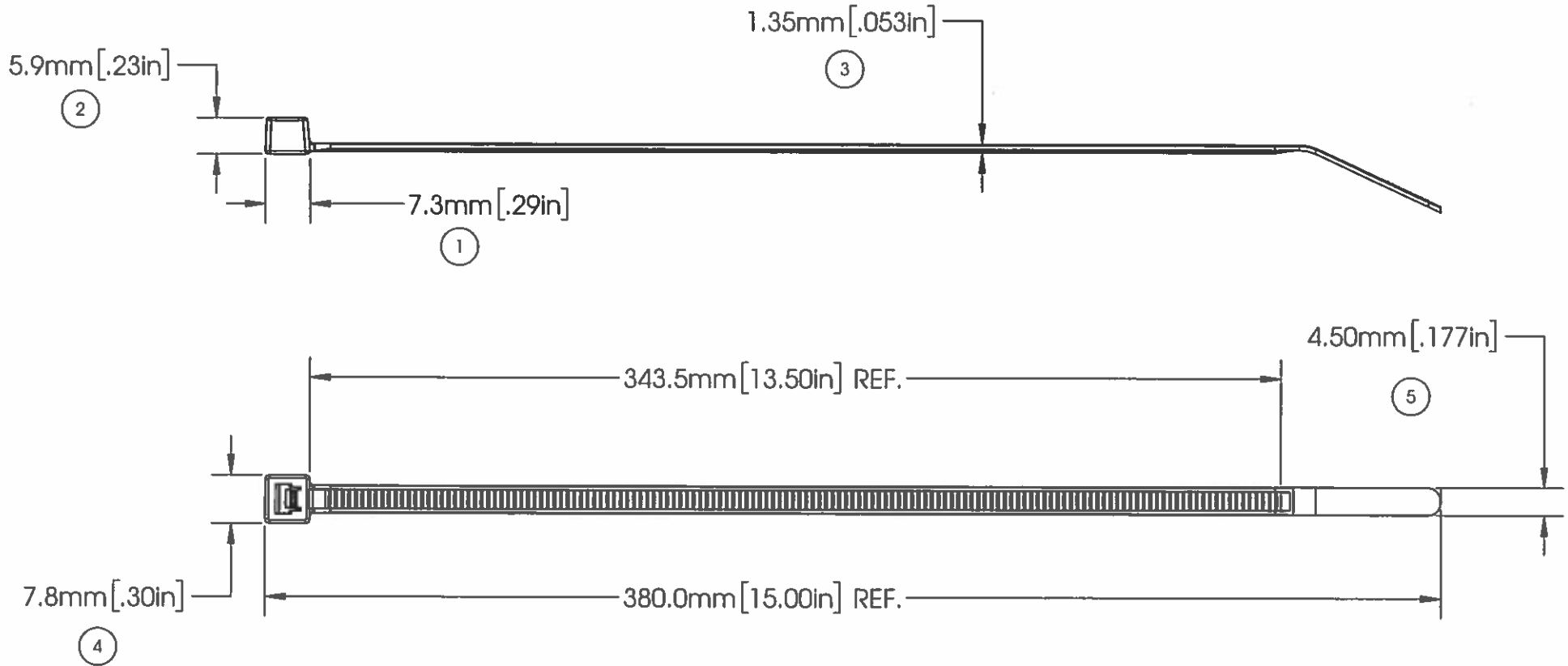

⑥	△ LOOP TENSILE:	50 LBF/220 N MIN.
⑦	△ FLAMMABILITY:	HB RATED PER FMVSS302
	OPERATING TEMP RANGE:	-40°F (-40°C) TO 302°F (150°C) CONTINUOUS AND 329°F (165°C) MAXIMUM EXPOSURE
	MIN. INSTALLATION TEMP:	32°F (0°C)
	WEIGHT:	2.2 g. / 0.08 oz
	BUNDLE DIAMETER:	∅ 1.6mm TO ∅ 101.6mm (0.06" -4")
	TOOL:	12001-0 - HAND TOOL 12500-0 - PNEUMATIC TOOL
	TOOL TENSION SETTING:	6-8
	PACKAGING:	100/BAG, 1000/CASE

NOTES:

1. △ INDICATES A SPECIAL CHARACTERISTIC

APPROVALS:	ENG. APPR.	DATE
	<i>[Signature]</i>	2/27/17
	<i>[Signature]</i>	2/27/17



AVERY DENNISON

FASTENER DIVISION
FITCHBURG, MA 01420 U.S.A.
TEL. 1-800-225-5913
FAX. 978-353-8157

SPECIFIED TOLERANCES ARE:		MATERIAL
.XX ± .03 in	.X ± .7 mm	NYLON 6/6, IMPACT MODIFIED HEAT STABILIZED
.XXX ± .010 in	.XX ± .25 mm	COLOR
ANGULAR: ± 2°		BROWN

DESCRIPTION	STOCK NO.	REV.
15" CABLE TIE, STANDARD, HIGH HEAT	08416-HHBN	A

5

4

3

2

1

AVERY DENNISON MARKETING SPECIFICATION

THE SUBJECT MATTER DISCLOSED HEREIN EMBODIES PROPRIETARY INFORMATION WHICH IS THE CONFIDENTIAL PROPERTY OF THE AVERY DENNISON CO. NONE OF WHICH SHALL BE COPIED, REPRODUCED, DISCLOSED TO OTHERS, PUBLISHED OR USED IN WHOLE OR IN PART, FOR ANY PURPOSE OTHER THAN THAT FOR WHICH IT IS BEING MADE AVAILABLE WITHOUT THE EXPRESS ADVANCE WRITTEN PERMISSION OF A DULY AUTHORIZED AGENT OF THE COMPANY. THIS DOCUMENT IS THE PROPERTY OF THE AVERY DENNISON CO. AND IS TO BE RETURNED TO THE COMPANY ON DEMAND.

HISTORY

REV.	DATE	DESCRIPTION
J	1.30.15	REDRAWN IN NEW FORMAT, ADDED UL INFORMATION AND LOGO
K	3.17.16	UPDATED DIM 5 TO BE 343.5mm TO MATCH NOMINAL MOLD DIM; UPDATED DIM 1 TO BE 7.3(TAKEN FROM THE BASE OF THE CABLE TIE HEAD)

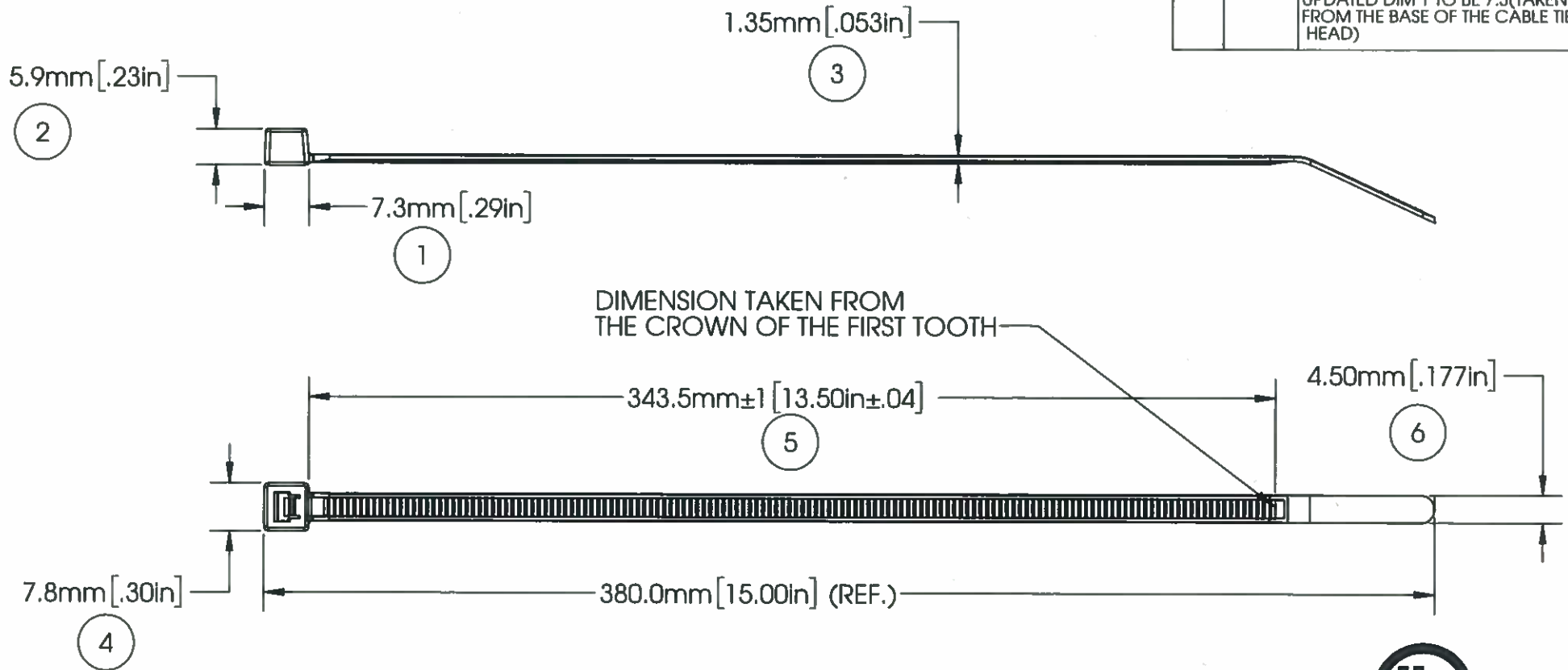

POSITIONING DEVICE
E57800
TYPE 21

NOTE: THESE CABLE TIES ARE PLENUM RATED AND HAVE A FLAMMABILITY RATING OF V-2

LOOP TENSILE STRENGTH:	50 LBF/220 N MIN. PER AS-23190
MILITARY STANDARD:	MS-3367-2-9
OPERATING TEMP RANGE:	-40°F (-40°C) TO 185°F (85°C)
MIN. INSTALLATION TEMP:	32°F (0°C)
WEIGHT:	2.35 g. / (0.0800 oz)
BUNDLE DIAMETER:	Ø 1.6mm TO Ø 101.6mm (0.06" - 4")
TOOL:	12001-0 - HAND TOOL 12500-0 - PNEUMATIC TOOL
TOOL TENSION SETTING:	6-8
PACKAGING:	100/BAG, 1000/CASE

APPROVALS: ENG. APPR. *[Signature]* 3/17/16
Q.A. APPR. *[Signature]* 3/17/16



AVERY DENNISON

FASTENER DIVISION
FITCHBURG, MA 01420 U.S.A.
TEL: 1-800-225-5913
FAX: 978-353-8157

SPECIFIED TOLERANCES ARE:	MATERIAL	DESCRIPTION
.XX ± .03 INCHES .X ± .7 mm	NYLON 6/6	15" CABLE TIE, STANDARD
.XXX ± .010 INCHES .XX ± .25 mm	COLOR	STOCK NO.
ANGULAR: ± 2°	NATURAL	08427-0
		REV. K

5

4

3

2

1

AVERY DENNISON MARKETING SPECIFICATION

THE SUBJECT MATTER DISCLOSED HEREIN EMBODIES PROPRIETARY INFORMATION WHICH IS THE CONFIDENTIAL PROPERTY OF THE AVERY DENNISON CO. NONE OF WHICH SHALL BE COPIED, REPRODUCED, DISCLOSED TO OTHERS, PUBLISHED OR USED IN WHOLE OR IN PART, FOR ANY PURPOSE OTHER THAN THAT FOR WHICH IT IS BEING MADE AVAILABLE WITHOUT THE EXPRESS ADVANCE WRITTEN PERMISSION OF A DULY AUTHORIZED AGENT OF THE COMPANY. THIS DOCUMENT IS THE PROPERTY OF THE AVERY DENNISON CO. AND IS TO BE RETURNED TO THE COMPANY ON DEMAND.

HISTORY

REV.	DATE	DESCRIPTION
J	1.30.15	REDRAWN IN NEW FORMAT, ADDED UL INFORMATION AND LOGO
K	3.17.16	UPDATED DIM 5 TO BE 343.5mm TO MATCH NOMINAL MOLD DIM; UPDATED DIM 1 TO BE 7.3(TAKEN FROM THE BASE OF THE CABLE TIE HEAD)

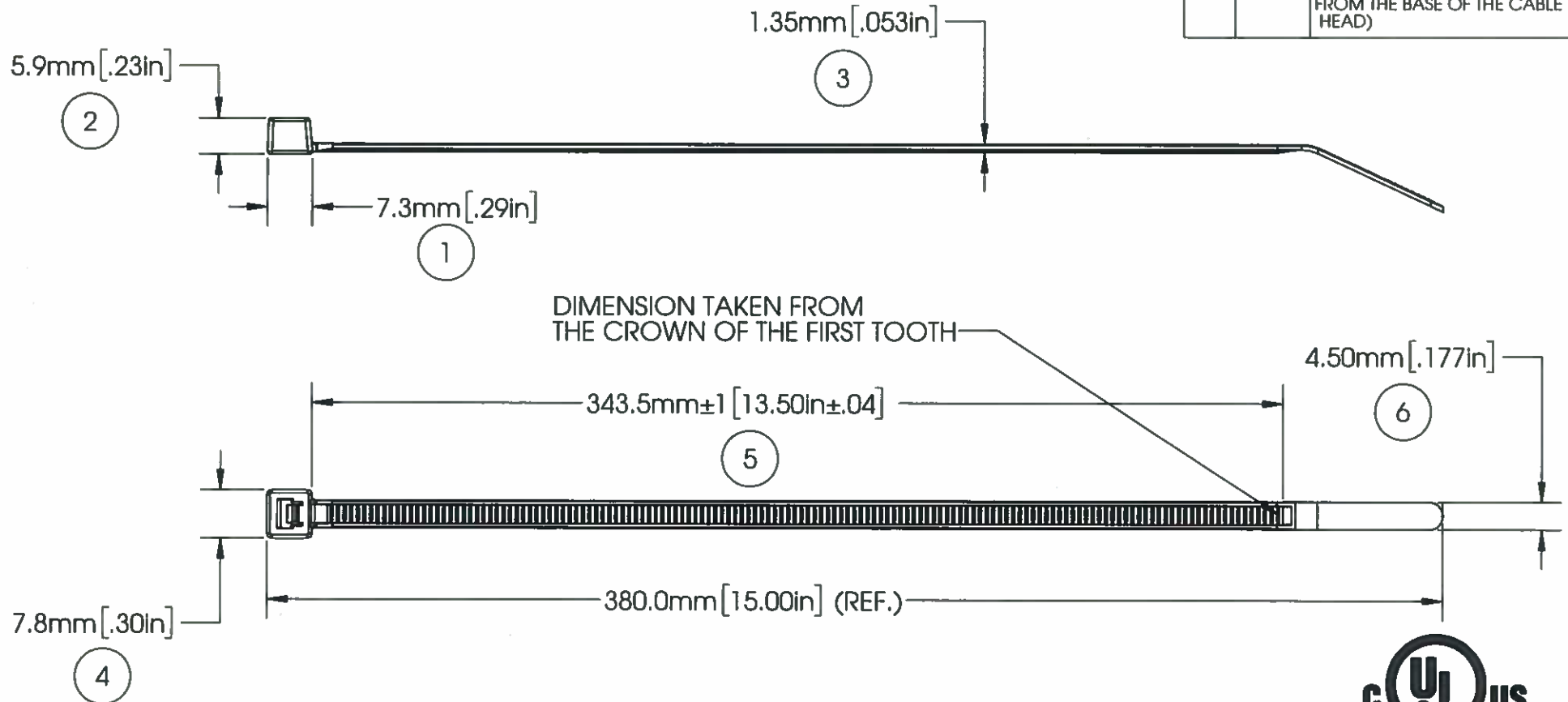

POSITIONING DEVICE
E57800
TYPE 21

NOTE: THESE CABLE TIES ARE UV RESISTANT AND HAVE A FLAMMABILITY RATING OF V-2

LOOP TENSILE STRENGTH:	50 LBF/220 N MIN. PER AS-23190
MILITARY STANDARD:	MS-3367-2-0
OPERATING TEMP RANGE:	-40°F (-40°C) TO 176°F (80°C)
MIN. INSTALLATION TEMP:	32°F (0°C)
WEIGHT:	2.35 g. / (0.0800 oz)
BUNDLE DIAMETER:	∅ 1.6mm TO ∅ 101.6mm (0.06" - 4")
TOOL:	12001-0 - HAND TOOL 12500-0 - PNEUMATIC TOOL
TOOL TENSION SETTING:	6-8
PACKAGING:	100/BAG, 1000/CASE

APPROVALS: ENG. APPR. *[Signature]* 3/17/16
Q.A. APPR. *[Signature]* 3/17/16



AVERY DENNISON

FASTENER DIVISION
FITCHBURG, MA 01420 U.S.A.
TEL. 1-800-225-5913
FAX. 978-353-8157

SPECIFIED TOLERANCES ARE:	MATERIAL	DESCRIPTION
.XX ± .03 INCHES .X ± .7 mm	NYLON 6/6, WEATHER RESISTANT	15" CABLE TIE, STANDARD
.XXX ± .010 INCHES .XX ± .25 mm	COLOR	STOCK NO.
ANGULAR: ± 2°	BLACK	08428-0
		REV. K

5 4 3 2 1

AVERY DENNISON MARKETING SPECIFICATION

THE SUBJECT MATTER DISCLOSED HEREIN EMBODIES PROPRIETARY INFORMATION WHICH IS THE CONFIDENTIAL PROPERTY OF THE AVERY DENNISON CO. NONE OF WHICH SHALL BE COPIED, REPRODUCED, DISCLOSED TO OTHERS, PUBLISHED OR USED IN WHOLE OR IN PART, FOR ANY PURPOSE OTHER THAN THAT FOR WHICH IT IS BEING MADE AVAILABLE WITHOUT THE EXPRESS ADVANCE WRITTEN PERMISSION OF A DULY AUTHORIZED AGENT OF THE COMPANY. THIS DOCUMENT IS THE PROPERTY OF THE AVERY DENNISON CO. AND IS TO BE RETURNED TO THE COMPANY ON DEMAND.

HISTORY		
REV.	DATE	DESCRIPTION
C	1.30.15	REDRAWN IN NEW FORMAT, ADDED UL INFORMATION AND LOGO
D	3.17.16	UPDATED DIM 5 TO BE 343.5mm TO MATCH NOMINAL MOLD DIM; UPDATED DIM 1 TO BE 7.3(TAKEN FROM THE BASE OF THE CABLE TIE HEAD)

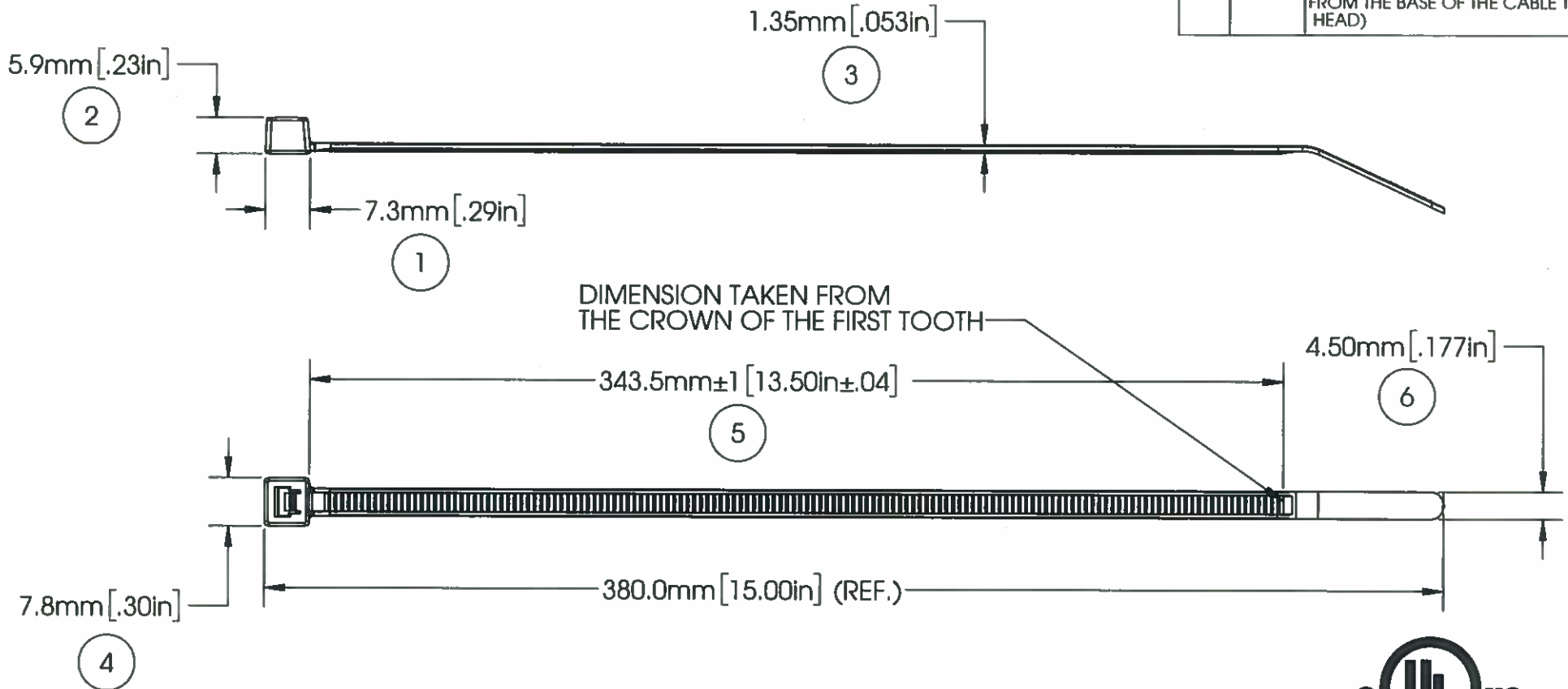

LISTED
POSITIONING DEVICE
E57800
TYPE 21

NOTE: THESE CABLE TIES ARE PLENUM RATED AND HAVE A FLAMMABILITY RATING OF V-2

APPROVALS: ENG. APPR. *[Signature]* 3/17/16
Q.A. APPR. *[Signature]* 3/17/16



AVERY DENNISON

FASTENER DIVISION
FITCHBURG, MA 01420 U.S.A.
TEL: 1-800-225-5913
FAX: 978-353-8157

LOOP TENSILE STRENGTH:	50 LBF/220 N MIN. PER AS-23190
MILITARY STANDARD:	MS-3367-2-9
OPERATING TEMP RANGE:	-40°F (-40°C) TO 185°F (85°C)
MIN. INSTALLATION TEMP:	32°F (0°C)
WEIGHT:	2.35 g. / (0.0800 oz)
BUNDLE DIAMETER:	Ø 1.6mm TO Ø 101.6mm (0.06" - 4")
TOOL:	12001-0 - HAND TOOL 12500-0 - PNEUMATIC TOOL
TOOL TENSION SETTING:	6-8
PACKAGING:	500/BAG, 5000/CASE

SPECIFIED TOLERANCES ARE:	
.XX ± .03 INCHES	.X ± .7 mm
.XXX ± .010 INCHES	.XX ± .25 mm
ANGULAR: ± 2°	

MATERIAL	NYLON 6/6
COLOR	NATURAL

DESCRIPTION	15" CABLE TIE, STANDARD	
STOCK NO.	10036-0	REV. D

5 4 3 2 1

AVERY DENNISON MARKETING SPECIFICATION

THE SUBJECT MATTER DISCLOSED HEREIN EMBODIES PROPRIETARY INFORMATION WHICH IS THE CONFIDENTIAL PROPERTY OF THE AVERY DENNISON CO. NONE OF WHICH SHALL BE COPIED, REPRODUCED, DISCLOSED TO OTHERS, PUBLISHED OR USED IN WHOLE OR IN PART, FOR ANY PURPOSE OTHER THAN THAT FOR WHICH IT IS BEING MADE AVAILABLE WITHOUT THE EXPRESS ADVANCE WRITTEN PERMISSION OF A DULY AUTHORIZED AGENT OF THE COMPANY. THIS DOCUMENT IS THE PROPERTY OF THE AVERY DENNISON CO. AND IS TO BE RETURNED TO THE COMPANY ON DEMAND.

HISTORY		
REV.	DATE	DESCRIPTION
C	1.30.15	REDRAWN IN NEW FORMAT, ADDED UL INFORMATION AND LOGO
D	3.17.16	UPDATED DIM 5 TO BE 343.5mm TO MATCH NOMINAL MOLD DIM; UPDATED DIM 1 TO BE 7.3(TAKEN FROM THE BASE OF THE CABLE TIE HEAD)

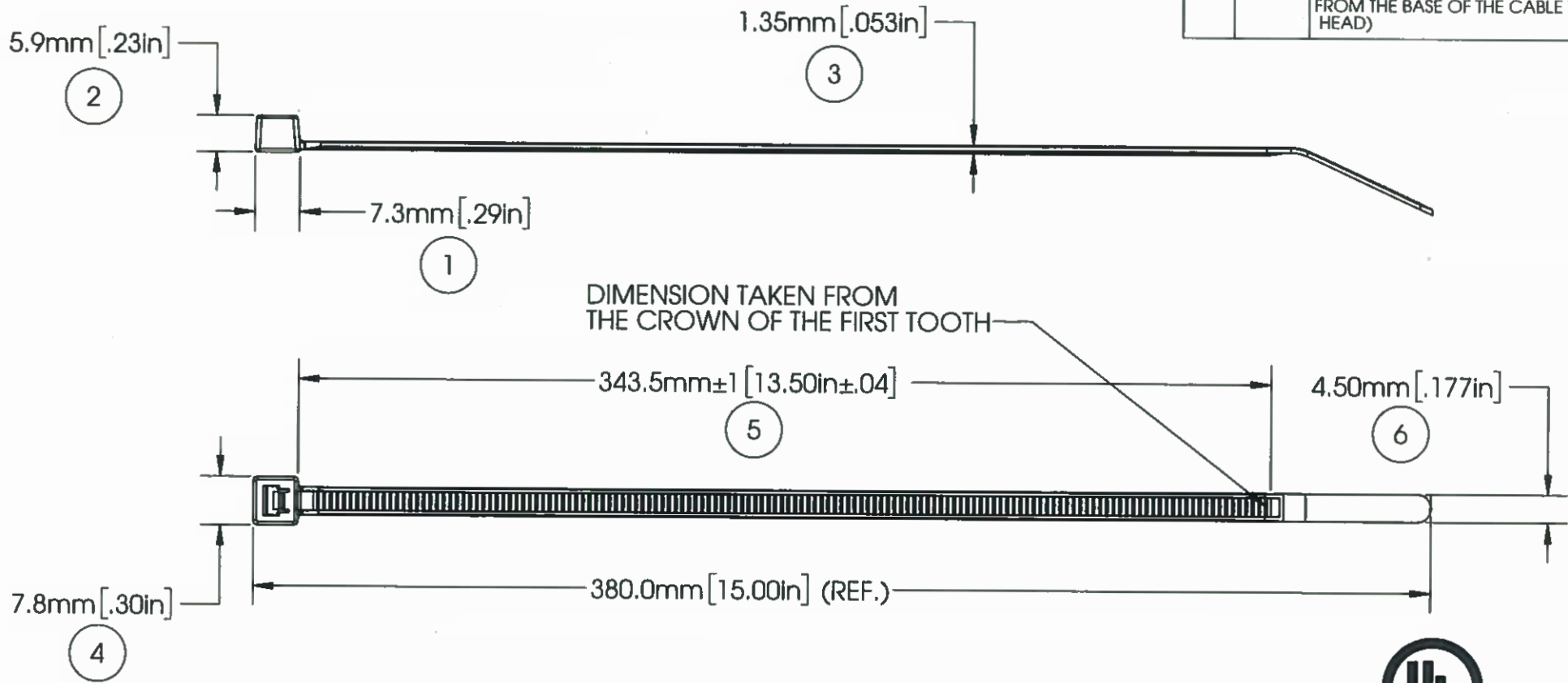

DIMENSION TAKEN FROM THE CROWN OF THE FIRST TOOTH



NOTE: THESE CABLE TIES ARE UV RESISTANT AND HAVE A FLAMMABILITY RATING OF V-2

LOOP TENSILE STRENGTH:	50 LBF/220 N MIN. PER AS-23190
MILITARY STANDARD:	MS-3367-2-0
OPERATING TEMP RANGE:	-40°F (-40°C) TO 176°F (80°C)
MIN. INSTALLATION TEMP:	32°F (0°C)
WEIGHT:	2.35 g. / (0.0800 oz)
BUNDLE DIAMETER:	Ø 1.6mm TO Ø 101.6mm(0.06" -4")
TOOL:	12001-0 - HAND TOOL 12500-0 - PNEUMATIC TOOL
TOOL TENSION SETTING:	6-8
PACKAGING:	500/BAG, 5000/CASE

APPROVALS: ENG. APPR. *[Signature]* 3/17/16
Q.A. APPR. *[Signature]* 3/17/16

AVERY DENNISON
FASTENER DIVISION
FITCHBURG, MA 01420 U.S.A.
TEL: 1-800-225-5913
FAX: 978-353-8157

SPECIFIED TOLERANCES ARE:		MATERIAL
.XX ± .03 INCHES	.X ± .7 mm	NYLON 6/6, WEATHER RESISTANT
.XXX ± .010 INCHES	.XX ± .25 mm	COLOR
ANGULAR: ± 2°		BLACK

DESCRIPTION	STOCK NO. 10037-0	REV. D
15" CABLE TIE, STANDARD		

AVERY DENNISON MARKETING SPECIFICATION

HISTORY

THE SUBJECT MATTER DISCLOSED HEREIN EMBODIES PROPRIETARY INFORMATION WHICH IS THE CONFIDENTIAL PROPERTY OF THE AVERY DENNISON CO. NONE OF WHICH SHALL BE COPIED, REPRODUCED, DISCLOSED TO OTHERS, PUBLISHED OR USED IN WHOLE OR IN PART, FOR ANY PURPOSE OTHER THAN THAT FOR WHICH IT IS BEING MADE AVAILABLE WITHOUT THE EXPRESS ADVANCE WRITTEN PERMISSION OF A DULY AUTHORIZED AGENT OF THE COMPANY. THIS DOCUMENT IS THE PROPERTY OF THE AVERY DENNISON CO. AND IS TO BE RETURNED TO THE COMPANY ON DEMAND.

REV.	DATE	DESCRIPTION
E	3.17.16	UPDATED DIM 5 TO BE 343.5mm TO MATCH NOMINAL MOLD DIM; UPDATED DIM 1 TO BE 7.3(TAKEN FROM THE BASE OF THE CABLE TIE HEAD)
F	7.19.19	DIM 5 WAS MADE A REF; ALL DIM RE-NUMBERED; ADDED NOTE 2; MADE TENSILE AND FLAMM. A SPECIAL CHAR.

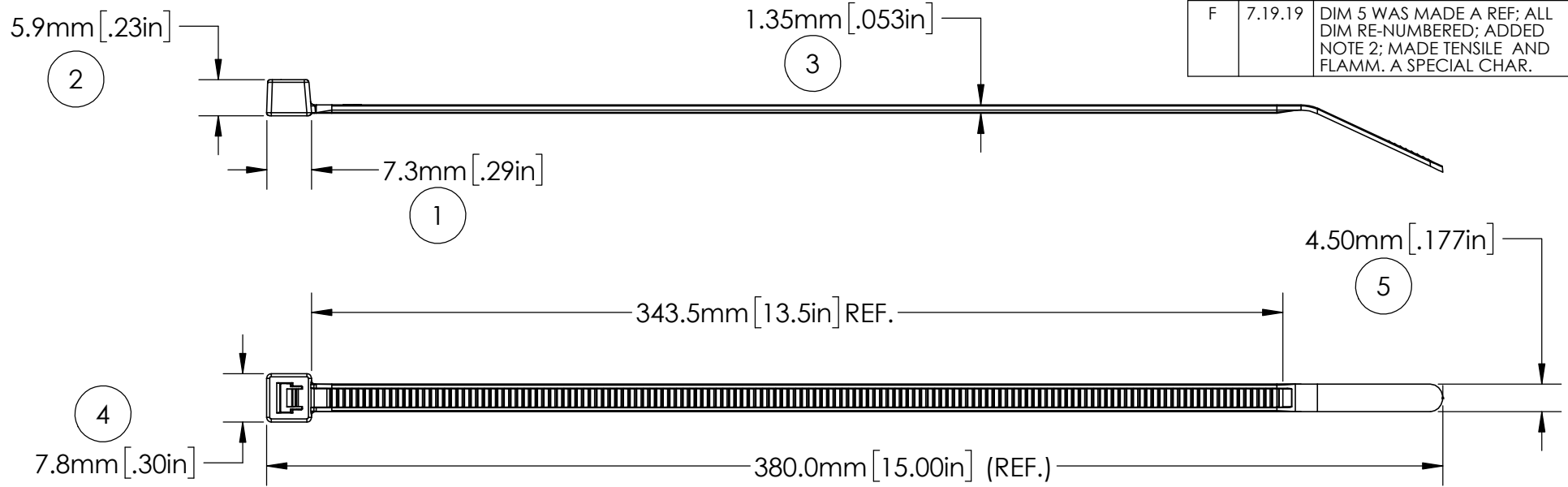

- NOTE:
1. THESE CABLE TIES ARE PLENUM RATED AND HAVE A FLAMMABILITY RATING OF V-2
 2. SPECIAL CHARACTERISTICS ARE DENOTED BY A TRIANGLE (Δ)

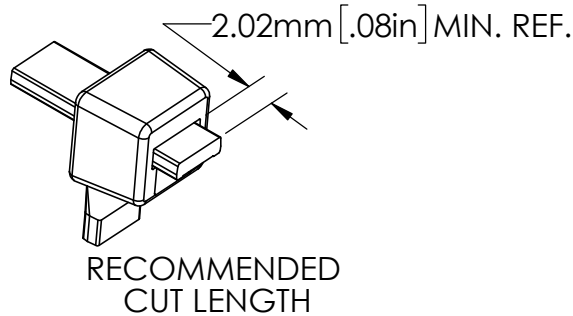

Δ	FLAMMABILITY:	HB RATED PER FMVSS302
Δ	TENSILE STRENGTH:	50 LBF/220 N MIN. PER AS-23190
	OPERATING TEMP RANGE:	-40°F (-40°C) TO 221°F (105°C)
	MIN. INSTALLATION TEMP:	32°F (0°C)
	WEIGHT:	2.35 g. / (0.0800 oz)
	BUNDLE DIAMETER:	ϕ 1.6mm TO ϕ 101.6mm(0.06" -4")
	TOOL:	12001-0 - HAND TOOL 12500-0 - PNEUMATIC TOOL
	TOOL TENSION SETTING:	6-8
	PACKAGING:	500/BAG, 5000/CASE

APPROVALS:	ENG. APPR. <i>Daniel Gilbertson</i>	07.19.19
	Q.A. APPR. <i>Caitlin Vaillancourt</i>	07.19.19

SPECIFIED TOLERANCES ARE:	
.XX \pm .03 INCHES	.X \pm .7 mm
.XXX \pm .010 INCHES	.XX \pm .25 mm
ANGULAR: \pm 2°	

MATERIAL	NYLON 6/6
COLOR	BLACK HEAT STABILIZED

AVERY DENNISON <small>FASTENER DIVISION FITCHBURG, MA 01420 U.S.A. TEL. 1-800-225-5913 FAX. 978-353-8157</small>	
DESCRIPTION	
15" CABLE TIE, STANDARD	
STOCK NO.	10408-0
REV.	F